



Navigation Receiver Module ML8088s

Operations Manual

Version 1.5

Saint Petersburg 2012

Table of Contents

Summary	3
List of Used Abbreviations	4
General Information	5
Specifications	7
Receiver Module Overall Dimensions	8
Recommended Footprint for the Receiver Module	9
Function of Connection Terminals	10
Typical Application Schematic	11
Using USB as NMEA interface	14
Receiver Module Control Interfaces	16
Switching module between constellations	16
Repairing procedure	19
Transportation and Storage	20

Summary

This document is designed for users of multi-channel navigation GLONASS/GPS/GALILEO receiving module ML8088s and contains the general description, specifications, application instructions, rules of operation, transportation, and storage.

List of Used Abbreviations

The list of adopted abbreviations is set out below:

- SS:** Space Satellite
- SC:** Satellite Constellation
- NT:** Navigation Task
- PC:** Personal Computer
- SW:** Software
- CT:** Standard Accuracy = **IT-Code:** Reduced Accuracy (former designation)
- NMEA:** Full name **NMEA 0183**, text protocol used for marine (normally navigation) equipment intercommunications (**National Marine Electronics Association**).

General Information

The exterior view of ML8088s navigation Receiver Module is shown in figure 1.



Fig. 1. The exterior view of the Receiver Module (not on 1:1 scale).

ML8088s receiving device of GLONASS/GPS/GALILEO multy-constellation Navigation System (hereinafter referred to as receiver or module) is designed for real-time calculation of current geographic coordinates and velocity of the target, generation of a time synchronization pulse called 1PPS and exchange with peripherals via RS232 serial ports or USB. The operating principle of the receiver is based on parallel receiving and processing of signals from navigation GLONASS SC by 32 counting channels in frequency band L1 (CT or PT code), GPS on L1 frequency (C/A code) and GALILEO on E1 frequency. NT solution results are issued in NMEA messages format.

ML8088s navigation receiver is built on a state-of-the-art dedicated chipset STA8088F from the family of so-called "systems-on-a-chip" STA8088FG.

The receiver has high sensitivity, low power consumption and short cold/warm/hot start time.

The receiver is provided with two searching (capturing) channels and 32 channels for satellite signals tracking, which ensures simultaneous searching for satellite signals of GLONASS and GPS constellations.

The receiver makes it possible to use satellites almanac and ephemeris data stored in the receiver memory for initial search of satellite signals; this ensures reduction of cold start time and, which is more important, makes it possible to perform the cold start when the signals from satellites are weak. The mentioned data can be prepared by external sources (and transferred to the receiver via data links), as well as by the receiver itself. In the latter case, no additional information from the external sources is required.

The receiver is provided with built-in 3-state jammer barrier feature, which allow the receiver to operate under high interference signaling environment.

The right-orientation key (the mark of the first connection terminal) is a black dot against the white background; the key is located in the top left corner of the label beside NAVIA logo.

The receiver operation control interface is performed with the use of special ST GNSS NMEA commands. Receiver has on board two UART parts and one USB.

The Demo board is released for user evaluation of the receiver module operation. The description of the board is provided in document Demo board ML8088s TD v1_0.pdf. The board can be connected to PC or other equipment for the receiver module operation analysis.

Specifications

Parameter	Value
Number of tracking channels	32
Number of capturing channels	2
GPS frequency band, MHz	1575.42 ±0.5
GLONASS frequency band, MHz	1,597.5...1,605.9
Coordinates calculation tolerance(at confidence probability level 0.67), maximum, m	3 in plan 4 by height
Plan velocity calculation tolerance (at confidence probability level 0.67), maximum, m/s	0.05
Tolerance of 1PPS distribution (at the gauss 70% distribution level) to time scales GPS, GLONASS, UTC, UTC (SU), average, ns	+20
Mean time to the first position measurement, at signal level -130 dBm, s	35 cold start 34 warm start 4 hot start 1 recapturing
Detection sensitivity, minimum, dBm	-145 cold start -145 warm start -153 hot start
Satellite positioning prediction, days	7 – external data source
Volume of satellites almanac and ephemeris data transmitted from the external source, KBytes	2
Tracking sensitivity, minimum, dBm	-158 in statics -155 in dynamics -151 in dynamics (error 30 m maximum)
Jammer barrier system	3 level, built-in
Output data updating rate, Hz	0.1... 1, 5
Dynamics, maximum	Acceleration, g rate of acceleration change, g/s 3 1
Maximum velocity, m/s	515
Maximum height, m	18,000
Microprocessor core	ARM946
Communications interface	RS232 3.3V LVCMOS, USB
1PPS signal	Level duration, ms 3.3 V LVCMOS 500
GNSS Status signal	Level=1,8V LVCMOS, duration 2sec, Time =4 sec
Main supply voltage, V	3.0...3.6
Backup supply voltage, V	2.0...3.6
Useful current in 3.3 V circuit, standard, mA	searching 55 (GPS), 75 (GLONASS+GPS) tracking 35 (GPS), 55 (GLONASS+GPS)
Useful current in external backup battery circuit, standard, uA	50
Dimensions (length x width x height), mm ³	15x13x2.8
Weight, maximum, g	2
Operating temperatures range, °C	-50C +90C

Receiver Module Overall Dimensions

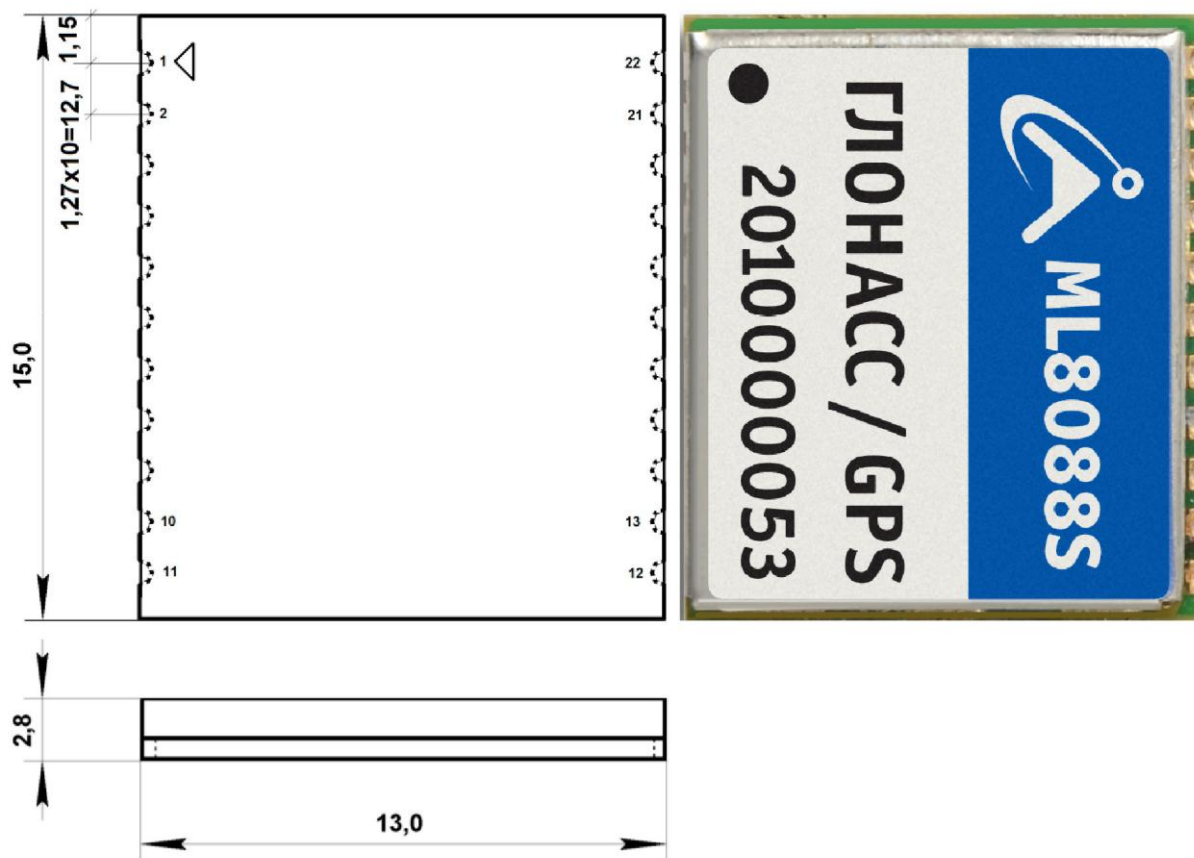

Fig. 2. Overall and Connection Dimensions of ML8088s Receiver Module. Terminal pads are shown in dashed line. Numbers of the terminals and the mark of the first connection terminal have conventional designations.

Recommended Footprint for the Receiver Module

The recommended footprint for ML8088s mounting on the user's PCB is shown in figure 3. All dimensions are in millimeters.

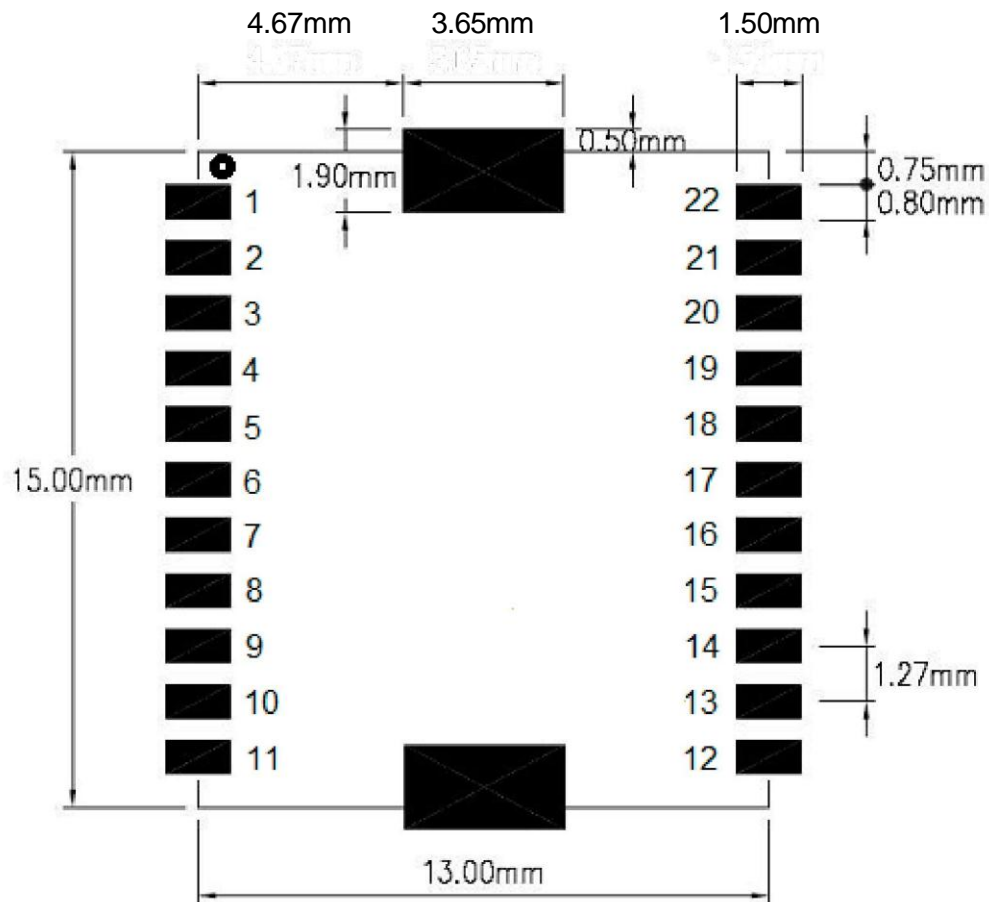

Fig. 3. Recommended footprint for ML8088s Receiver Module. Numbers of the connection terminals and the mark of the first connection terminal have conventional designations.

No signal lines should be placed under the module. It is recommended that the free space under the module be filled with GND polygon.

Function of Connection Terminals

Signal description	Type	Terminal number	Designation
Ground of the high-frequency part	Power	20, 22	RF GND
Ground of the digital part	Power	6, 17	GND
Antenna input	Analog	21	IN RF
Power supply +3.3 V	Power	13	V_IN
Backup battery circuit power supply	Power	12	V_RTC
UART1 Output (NMEA)	In/Out	4	TX1 (NMEA)
UART1 Input (NMEA)	In/Out	5	RX1 (NMEA)
UART0 Output	In/Out	2	TX0
UART0 Input	In/Out	1	RX0
USB D+	In/Out	15	USB_DP
USB D-	In/Out	16	USB_DM
1PPS signal	In/Out	3	PPS
Reception status	In/Out	8	GNSS status
Module hardware reset	In	18	$\overline{\text{RST}}$
Not connected	---	7, 9, 10, 11, 14, 19	NC

The states of bidirectional connection terminals in working mode of the Receiver Module operation are shown in bold letters.

Typical Application Schematic

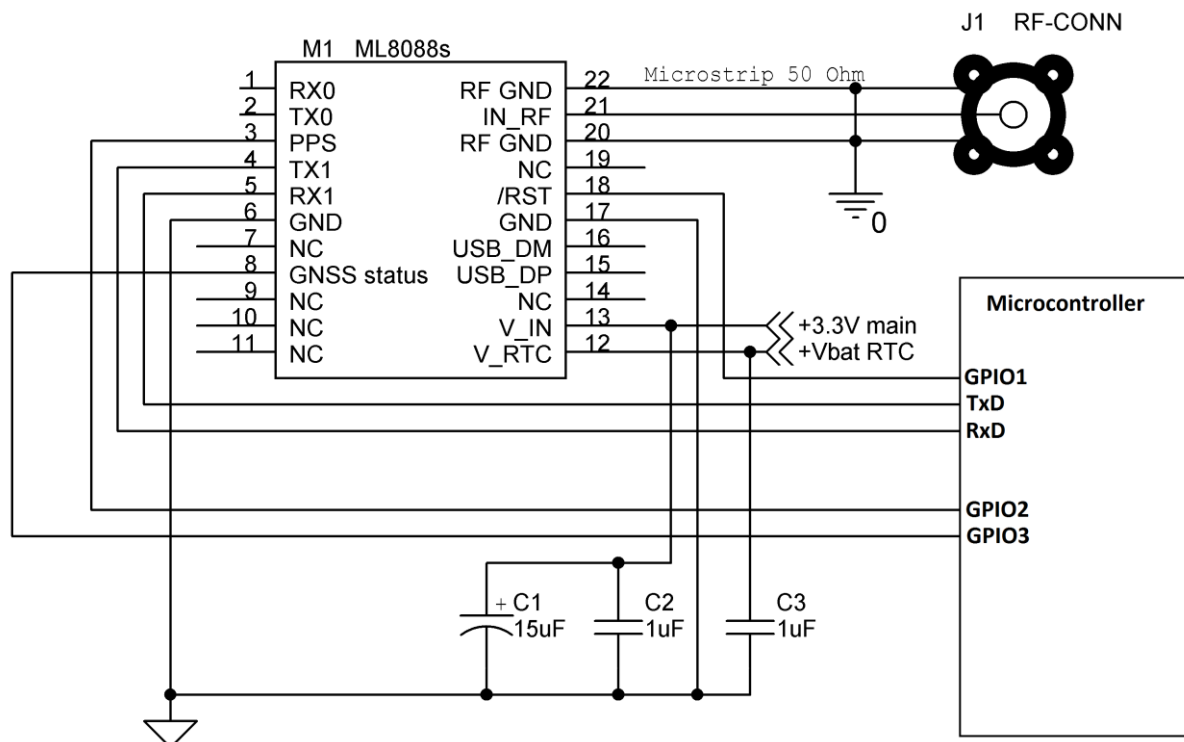

Fig. 4. ML8088s Receiver Module standard connecting diagram.

Figure 4 shows the standard application diagram of ML8088s Receiver Module. The arrows designate the directions of signals propagation – input signals of the Receiver Module are designated with arrows "to the Receiver Module", output signals are designated with arrows "from the Receiver Module".

The module supply voltage $V_{dd} = 3.0...3.6$ V is applied to termination pad 13 (V_IN). In the connecting diagram, this pad is designated as **+ 3.3 V main**.

Voltage from the backup battery within the range of $V_{bat} = 2.0...3.6$ V must be applied to termination pad 12 (V_RTC). In the connecting diagram, this circuit is designated as **+V_{bat} RTC**. It is recommended that V_{bat} be constantly maintained for assurance of built-in clock and module RAM memory operation. In addition, the backup battery voltage provides power for the module internal Firmware (the module FW) activation attribute storage latch register. Use of a backup battery whose voltage exceeds the module supply voltage is not recommended ($V_{bat} \leq V_{dd}$).

AT ONLY FIRST TIME when the module supply voltage V_{dd} is switched "ON", following V_{bat} also switched "ON", be sure to send a low logic level pulse to terminal pin18 /Reset in, designation in the diagram /Reset in. This is required for selection of operation mode for the integrated microcontroller of the module (operation or storing of the program in the built-in flash SQI memory), for activation of the module internal FW and saving of its activation attribute into the storage latch register. The pulse duration must be at least 10 ms, the input voltage must not exceed 0.1 V, the source output capability must be at least 8 mA. At subsequent switching-on of V_{dd} supply voltage, sending of the pulse to input is non-mandatory, since sending of this signal causes erasing of current time information in RTC, which increases the time of satellites searching and capturing. The signal states and levels timing diagram at the module connection terminals at V_{bat} and V_{dd} switching-on is shown in figure 5.

It should be taken into account that the states and signals are described in reference to the external peripheral control system (e.g., external peripheral MCU). Therefore, the data at TxD0

output of the module is described in the figure as "Input data" (input data for the external peripheral system), while the data at RxDO input of the module is described as "Output data" (output data from the peripheral system). High impedance Z state describes the connection terminals of the peripheral system (inputs and outputs) connected to the relevant connection terminals of the module.

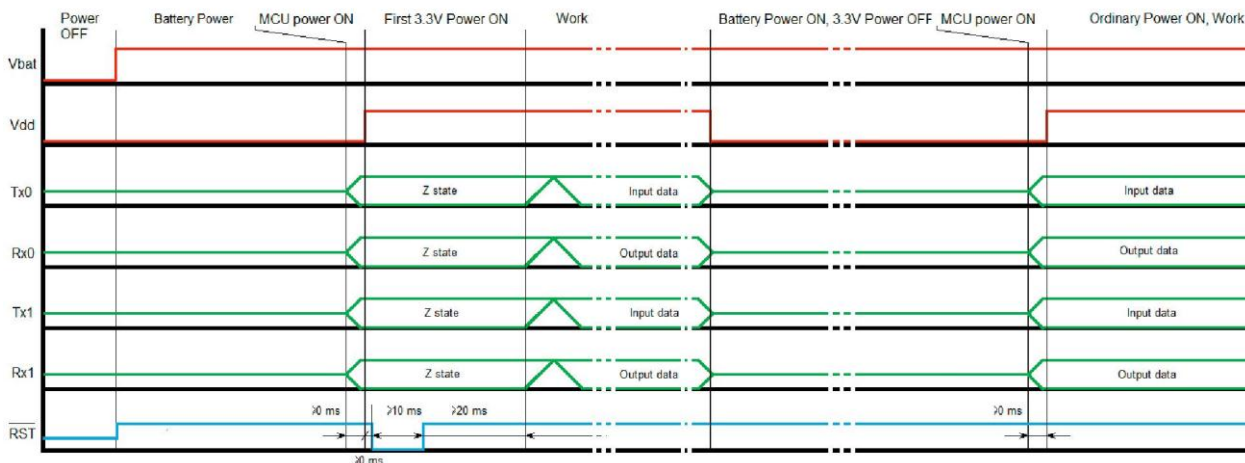

Fig. 5. The signal states and levels timing diagram at the module connection terminals at Vbat application.

The connection terminals of the peripheral control system must in no time be the power sources of the module (the so-called phantom power), i.e., voltages at connection terminals TxDO, RxDO, TxD1 and RxD1 must not exceed the module supply voltage at any time. Clearly, with V_{dd} switched-off, there must be no voltage on the said connection terminals; for example, if the connection terminals are switched to high-impedance Z state, input mode or into Logical 0 state, there must be no supply voltage "pull-up" on them.

The moment the pulse is sent to input (or, if this pulse is not generated but instead on the module supply voltage V_{dd} is applied without applying of $+V_{bat}$), be sure to provide for high-impedance state (Z state or Input state) of the circuits connected to TXD0 and TXD1 terminals. In doing so, be aware that there should be no leakages through protection circuits of connected connection terminals caused by overvoltage up to V_{dd} value. Failure to meet this requirement will render correct launching of the module internal software impossible. The said states should be maintained for at least 20 ms from the moment the sending of low level to input is over or from the moment V_{dd} supply voltage is switched on (if V_{bat} is not used).

If the backup battery is not used, sending of the pulse to input is non-mandatory. The signal states and levels timing diagram at the module connection terminals at V_{dd} switching-on without V_{bat} being used is shown in figure 6.

he pulse can be sent to input for restart of the module internal program.

The antenna (active or passive) is connected to terminal 21 (IN_RF). In the connecting diagram, antenna is designated as **A1**. The conductor, connecting terminal 21 of the Receiver Module with the antenna, must be implemented as microwave PCB line with wave resistance 50 Ohm. Terminals 20 and 22 (RF GND) of the module are the high-frequency ground circuit for terminal 21 (designated in the diagram as "shaded" ground). The power to the active antenna for receiving of signals from satellites shall be connected via built-in circuits of the module. The supply circuit of the active antenna is protected inside of the module with a resettable fuse with trip current 100 mA. If the active antenna is used, provision should be made for the relevant load characteristics of the module power supply.

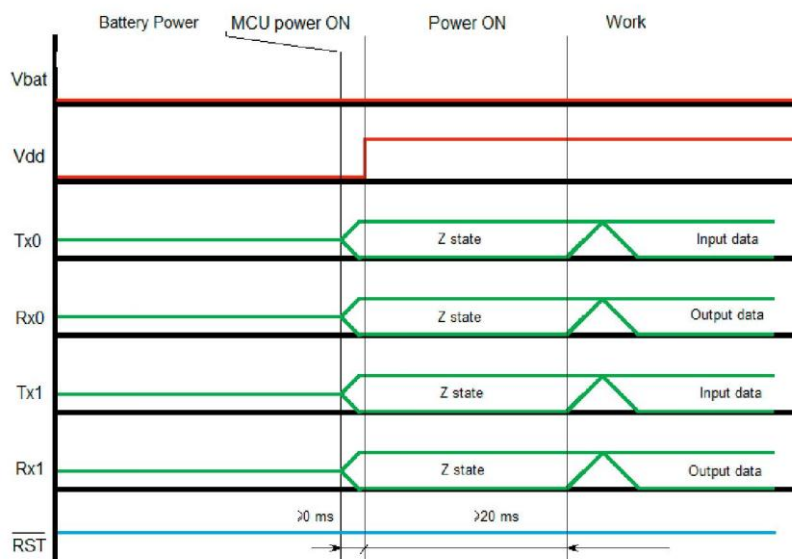

Fig. 6. The signal states and levels timing diagram at the module connection terminals when the module is used without Vbat.

The output signal as a sequence of NMEA messages is generated via UART1 serial port (signal TX1 pad 4, signal RX1 pad 5). NMEA messages are present on this port in as built state. These signals are designated in the diagram as **UART1 Tx** and **UART1 Rx** respectively. As alternative NMEA messages and command can provided via USB in/out.

Setting of the exchange rate via UART serial port, selection of GLONASS, GLONASS/GPS or GPS satellite constellations and other setups are performed through sending of special NMEA messages to the module.

UART0 port signals have output to terminals 1 and 2 of the Receiver Module (signal TX0 pad 2 and signal RX0 pad 1). In factory default setting, this port is designed for programming of the Receiver Module built-in flash SQI memory. Depending on the program setups of the module, this port can be designed for transferring of information about differential corrections to the Receiver Module, receiving of NMEA messages, loading of information about satellite environment, etc. These signals are designated in the diagram as **UART0 Tx** and **UART0 Rx** respectively.

UART0 serial port (signal TX0 pad 2, signal RX0 pad 1).

1PPS time synchronization signal has output to pad 3. This signal can be used by the consumer's equipment for precise binding of the device time to UTC standard time. In the connecting diagram this signal is designated as **1PPS OUT**.

GND circuit (Ground) (terminals 6 and 17) must be connected to **GND** circuit (Ground) of the peripheral device the module is used in.

Circuits GND and RF GND actually connected to each other inside of the module but must be NOT connected outside of the module to avoid possible interference to Antenna signal. As showed on the application circuit the GND pins 22 and pins 20 connected ONLY to the Antenna connector's Ground!

ATTENTION! Antenna input pin 21 connected internally to the 3.3 V used to powering active antenna. In case of connection to pin 21 a device with low active impedance (for example GNSS Simulator 50 Ohm matching transformer at the output) a certain Capacitor must be used to avoid short device burning.

Using USB as NMEA interface

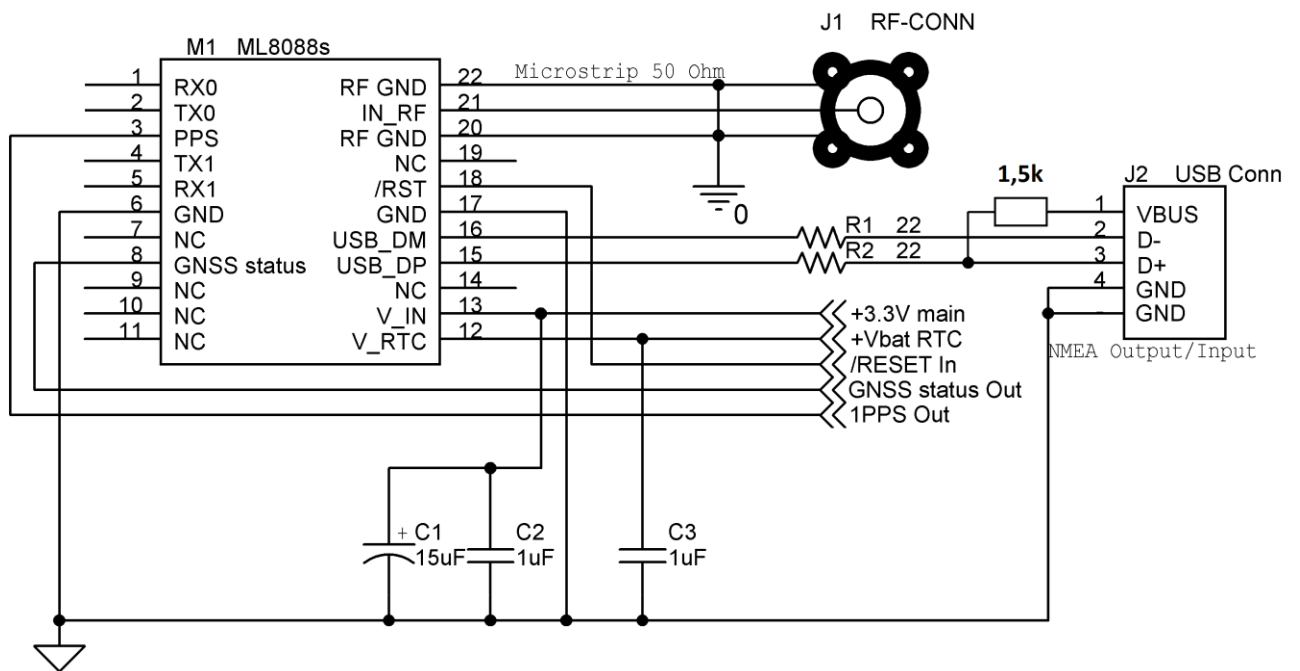

Pic.7 Typical application circuit ML8088s using USB interface for NMEA transmission.

Picture 7 illustrate possible ML8088s connection via USB to get NMEA data and control command send. Using this circuit please remind that NMEA data is not come through UART1 when using USB! To switch module in USB mode user must either download corresponded firmware or sending to the module special command using “Navia GLONASS+GPS” software. Connector USB J2 showed on above schematic with mini-USB pinning. Resistors R11 and R12 used to matching pin-outs of module with external USB bus, for most application a 22R can be applied.

GNSS status signal (terminal 8) is designed for hardware notification of external user about the fact that the navigation task is successfully solved (coordinates are found). In the absence of successful solution to the navigation task, this signal is constantly held in "log.0" state. In the presence of a successfully solved navigation task, the state of the signal changes every 2 seconds from "log.0" to "log.1" and back.

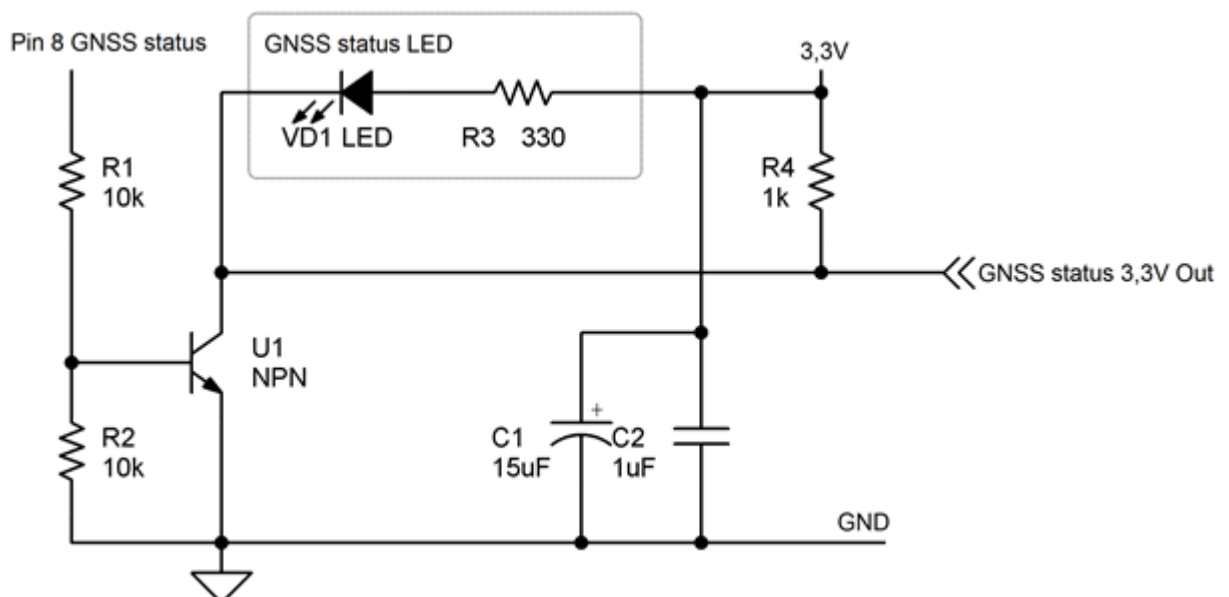

Pic.8 Typical application circuit converting output signal GNSS Status from the module to 3,3V and LED blinking status.

The GNSS status signal from the module has amplitude 1,8V max. To match with 3,3V application a certain application circuit showed on Pic. 8 can be used. In case the navigation task is successfully solved, VD1 LED shown in the connecting diagram glows for 2 seconds and does not glow for 2 seconds (i.e. slowly flashes). In addition, this signal can be sent to other elements of the device the module is used in (e.g., to the peripheral microcontroller)

Receiver Module Control Interfaces

The Receiver Module operation control interface is performed with the use hardware features, as well as with special commands issued to the Receiver Module. The hardware features ensure hardware reset and selection of work/programming mode of functioning. For hardware reset of the Receiver Module, a low logic level pulse is sent to /RESET input. The parameters of the pulse explained above on page 12 pic.5. For selection of work/programming mode of functioning, relevant logical levels applied to connection terminals TX0 and TX1 at the moment of the Receiver Module hardware reset pulse generation. In order to ensure functioning of the Receiver Module in work mode, hold connection terminals TX0 and TX1 in Input state or high input impedance (Z state) at the moment of the Receiver Module hardware reset pulse generation or for at least 20 milliseconds following its completion. In order to switch the Receiver Module into programming mode, hold TX0 connection terminal in input state or high input impedance (Z state) and TX1 connection terminal – in 0 (low logical level) state at the moment of the Receiver Module hardware reset pulse generation or for at least 20 milliseconds following its completion.

A set of special commands with NMEA-like format is designed for control of program modes and parameters of the Receiver Module. The commands are issued to RX1 input or USB. The description of the commands is provided in document The Set of NMEA Commands of ML8088s Receiver Module.pdf (available for developers upon request).

Switching module between constellations

Module can be switched in to 3 modes:

1. Combine GLONASS + GPS reception – give most excellent accuracy and reception stability
2. GLONASS reception only
3. GPS reception only

Switching between modes can be done in two different ways:

1. “on the fly” by using the follow special command:
 - \$PSTMSETCONSTMASK,2 – for GLONASS only
 - \$PSTMSETCONSTMASK,1 – for GPS only
 - \$PSTMSETCONSTMASK,3 – for GLONASS+GPS mode

This type of standard switch is most fast and do not required hardware reset. But after power on the standard type will be reset to default!

2. by sending commands type \$PSTMxxx to NMEA port with following hardware RESET by applying low level pulse to pin 18 (/RES) module. **Ignore this point can be a cause of incorrect module working or halting module.**

Below please find a gropes of certain commands:

1. Combine mode:
\$PSTMSETPAR,1200,00630000,1*
\$PSTMSAVEPAR
2. GLONASS Only:
\$PSTMSETPAR,1200,00410000,2*
\$PSTMSETPAR,1200,00220000,1*

\$PSTMSAVEPAR

3. GPS Only:

\$PSTMSETPAR,1200,00220000,2*

\$PSTMSETPAR,1200,00410000,1*

\$PSTMSAVEPAR

This type of mode switching modify the NVM configuration parameters therefore after power on or Reset stay without change!

Maintenance

The Receiver Module does not require special types of maintenance.

Repairing procedure

The Receiver Module does not require any permanent repair, provided that the rules of operation set forth in this Operations Manual, and requirements for operation, storage and transportation conditions are observed. If failures occur, the Receiver Module must be returned to the manufacturer for subsequent repair.

Transportation and Storage

Packed Receiver Module units can be transported by all transportation vehicles over distances up to 20,000 km without speed limitation at temperatures from -40°C to $+85^{\circ}\text{C}$, subject to protection of Receiver Module units from direct atmospheric exposure and mechanical damage according to the rules that comply with requirements of GOST 23088. The storage life of a packed Receiver Module in heated storage facilities with controlled ambient temperature from $+5$ to $+35^{\circ}\text{C}$ and relative air humidity up to 80% at $+25^{\circ}\text{C}$ temperature is 10 years minimum.